

Digital Gauss/Tesla Meter

CYGM99B

User's Manual
Version 2: 09.03.2023



ChenYang Technologies GmbH & Co. KG

Markt Schwabener Str. 8
85464 Finsing, Germany
Tel. +49-(0)8121-2574100
Fax: +49-(0)8121-2574101
Email: info@chenyang.de
<https://www.chenyang-gmbh.com/>

The Gaussmeter CYGM99B works according to Hall Effect measuring principle. It is a system with an embedded microcontroller and can be used to measure DC/AC magnetic field density of permanent magnet materials, motors, speakers, magnetic sensors/ transducers, other machines, and instruments etc. with high resolution. It is powered with one LiPo battery (+3.7V) or via USB cable (+5VDC).

1. Characteristics

- Rechargeable LiPo battery
- Wide measuring range and high resolution.
- A low-cost measuring device, which is easy to operate, portable and convenient to handle and store, rechargeable battery.
- Ideal for quick quality checks and comparative measurements, with built-in polarity display.
- Data communication with computer via USB cable for further signal processing.
- Remote control by computer.

2. Technical Data

Measuring ranges:	0-50mT and 0-500mT, 0-200mT and 0-2000mT, 0-300mT and 0-3000mT
Basic accuracy:	DC: $\pm 1.0\%$, AC: $\pm 2.0\%$
Resolution:	DC/AC x1: 0.0 ~ 50.000mT, 0.001mT DC/AC x10: 0.0 ~ 500.00mT, 0.01mT DC/AC x1 0.0 ~ 200.00mT, 0.01mT DC/AC x10 0.0 ~ 2000.0mT, 0.1mT DC/AC x1 0.0 ~ 300.00mT, 0.01mT DC/AC x10 0.0 ~ 3000.0mT, 0.1mT
Measuring magnetic field:	DC/AC (static & dynamic field)
Frequency range:	DC, 10Hz ~ 10kHz
Functions:	Range x1/x10 selection Unit mT/Gs selection, Local/remote control Probe zero adjustment N/S pole display for DC measurement RMS/Peak value for AC measurement Max hold, Min hold, Display hold
Display:	5 Digit LCD
Display Unit:	mT/Gs (1mT=10Gs)

Ambient temperature: +5°C ~ +50°C
 Storage temperature: -20°C ~ +70°C
 Relative humidity: 20% ~ 80%
 Power supply: 3.7V LiPo battery or USB 5V
 Dimensions: 190mm x 90mm x 33mm
 Weight: 365g

3. Accessories

- 1 x 3.7V LiPo battery
- 1 x Hall probe CYTP98[A/B/C] or CYAP98[A/B/C]
- 2 x 0.9m USB Cable
- 5V DC Voltage adapter (standard mobile phone charger)

4. Hall probes

Probe Name	transversal probe		
Part number	CYTP98A	CYTP98B	CYTP98C
Measuring range	0-50mT	0-200mT	0-300mT
	0-500mT	0-2000mT	0-3000mT
Probe size	1.5x4x65mm, custom-made: 0.95x4x65mm		
Picture			

Probe Name	axial probe		
Part number	CYAP98A	CYAP98B	CYAP98C
Measuring range	0-50mT	0-200mT	0-300mT
	0-500mT	0-2000mT	0-3000mT
Probe size	Ø7 x 80mm		
Picture			

5. Measuring Principle

The Gaussmeter CYGM99B works according to Hall Effect principle. There are two kinds of Hall probes: transverse and axial probes, which are used for different magnetization directions.

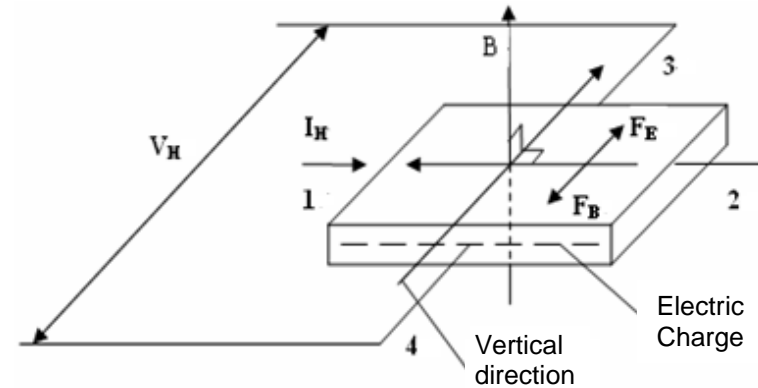

Hall Effect and its Electrical Parameters

According to the Hall Effect, a voltage can be measured at right angle to the current path when a conductor or semiconductor with current flowing in one direction is introduced perpendicular to a magnetic field. The Hall voltage can be calculated from:

$$V_H = k_H I_H B$$

Where: V_H : Hall voltage in volts
 B : the applied field in Gauss
 k_H : sensitivity of the element in volts/Gauss
 I : bias working current in Amperes

The initial use of this discovery was for the classification of chemical samples. The development of indium arsenide semiconductor compounds in the 1950's led to the first useful Hall Effect magnetic instruments. Hall Effect sensors allowed the measurement of DC/AC (static/dynamic) magnetic fields without requiring motion of the sensors.

6. Measuring Method

The magnetic lines of the measured magnetic field should perpendicularly pass through the Hall Effect element of the Hall probe. Put the Hall probe on the surface of the measured magnet or at the measuring point of a magnetic field carefully.

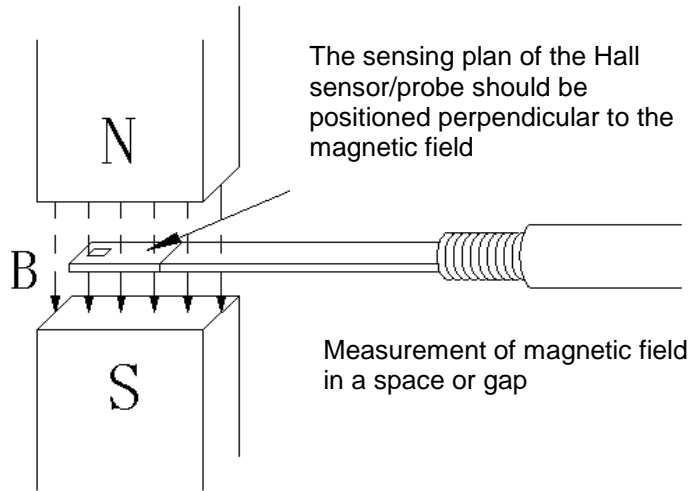

Measurement of surface flux density of a magnet

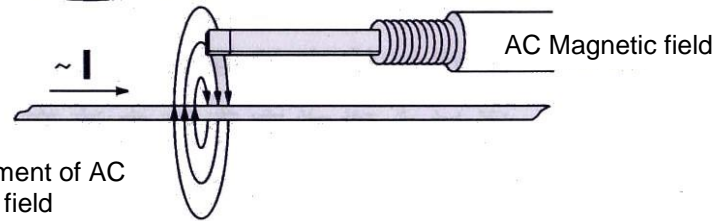
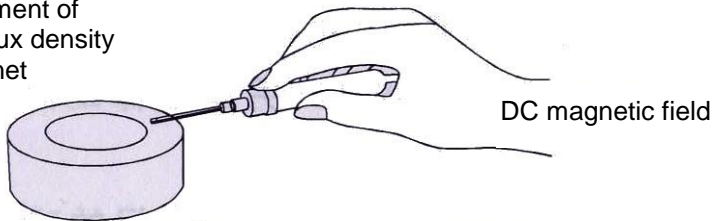

Measurement of AC magnetic field generated by AC current.

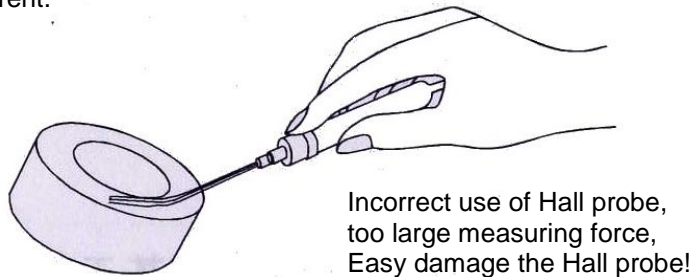

7. Part and Functions

Front Panel

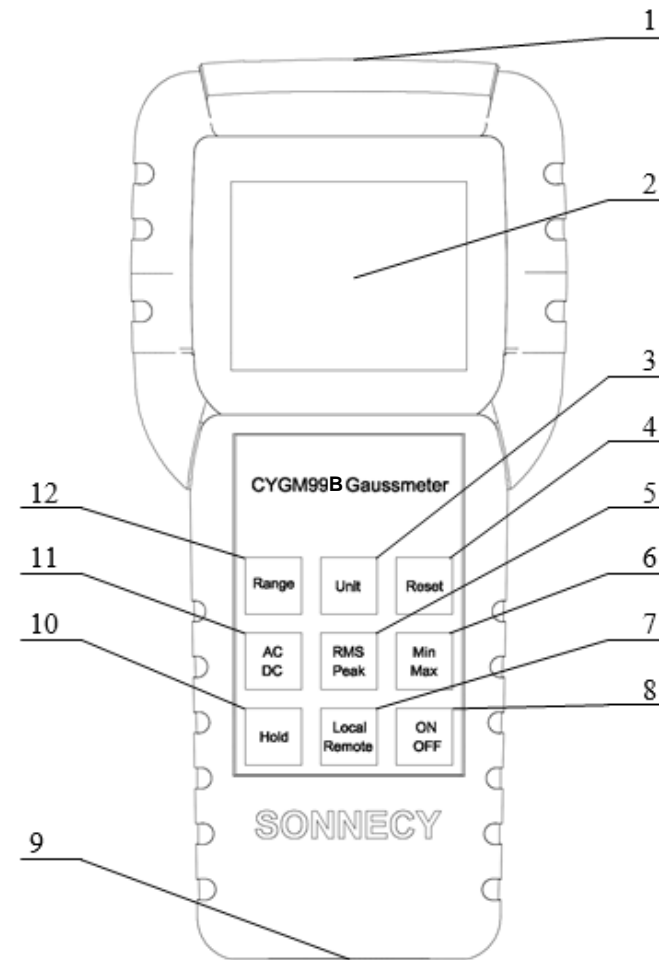

- | | | |
|---|---------------------|-------------------|
| 1: USB A port for probe | 2: LCD | 3: Unit selection |
| 4: Zero reset | 5: RMS/Peak select | 6: Max/Min hold |
| 7: Local/Remote select | 8: Power switch | 10: Display hold |
| 11: AC/DC mode | 12: Measuring range | |
| 9: USB micro B port for PC connection and charging port | | |

Hall probe

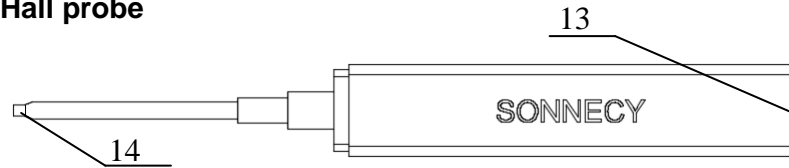

13: USB microB port for measuring instrument 14: Hall chip

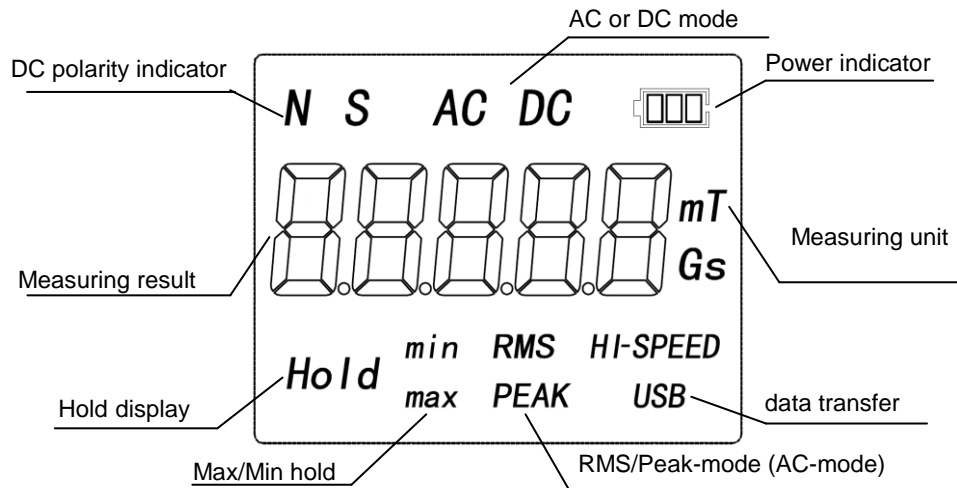

Functions:

- 1) **USB A port for probe:** to connect the Hall sensor/probe to the measuring instrument.
- 2) **LCD:** to display the field strength and pole direction ("N" north pole, "S" south pole) etc.
- 3) **Unit selection:** select the display unit (Gs or mT).
- 4) **Zero reset:** reset the measuring value.
- 5) **RMS/Peak select:** select the display format of AC signal (RMS value or Peak value).
- 6) **Max/Min hold:** hold the max/min value.
- 7) **Local/Remote select:** to select the control mode (local or remote).
- 8) **Power switch:** to switch ON/OFF the measuring instrument.
- 9) **USB micro B port for PC connection:** to connect the external 5V power supply and for data communication between Gaussmeter and PC

- 10) **Display hold:** hold the current value.
- 11) **AC/DC mode:** select the measurement of AC or DC magnetic field.
- 12) **Measuring range:** select the measuring between range 0-50mT and 0-500mT for Hall Probes CYTP98A and CYAP98A or between 0-200mT and 0-2000mT for Hall Probes CYTP98B and CYAP98B or between 0-300mT and 0-3000mT for CYTP98C and CYAP98C.
- 13) **USB microB port of Hall probe:** connect the Hall probe to the measuring instrument.

8. Measuring Procedure

- 1) Connect the Hall probe (13) to the measuring instrument (1) via micro USB cable.
- 2) Connect the LiPo Battery to the board by connecting the cable in the battery bay.
- 3) Switch on the power of measuring instrument by pressing "ON/OFF" button (8), LCD display shows 0000.0mT or other value.

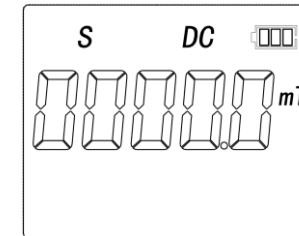

- 4) **Select measuring range** by pressing the "Range" button (12), the measuring range changes between 0-200mT and 0-2000mT as follows (as example by using Hall probe CYTP98B or CYAP98B):

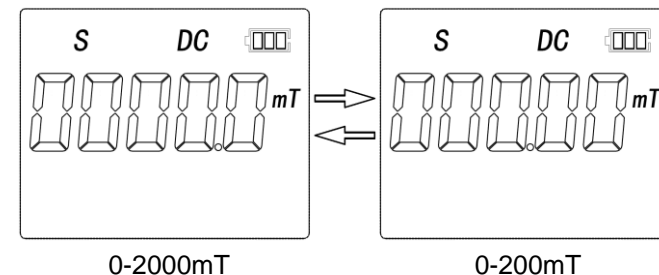

- 5) **Select AC/DC Mode** by using the “AC/DC” button (11), the display shows the following DC or AC measuring mode:

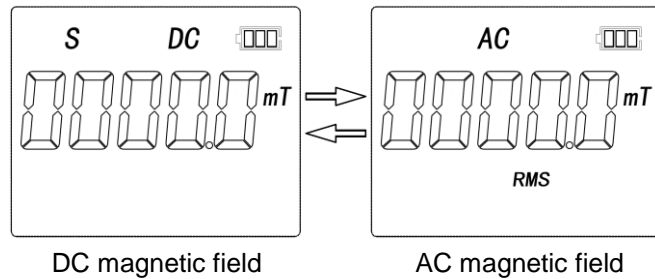

“N” north pole, “S” south pole for DC magnetic field

- 6) **Select unit** by pressing “Unit” (3), unit changes between Gs and mT

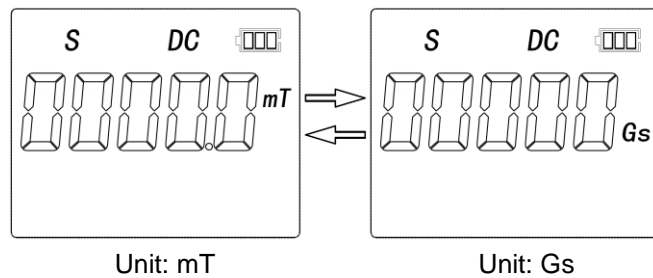

- 7) **Reset Gaussmeter.** Keep the Hall probe far away from magnetic field or put it in a Zero point calibrator , LCD display shows zero after pressing “Reset” button (4):

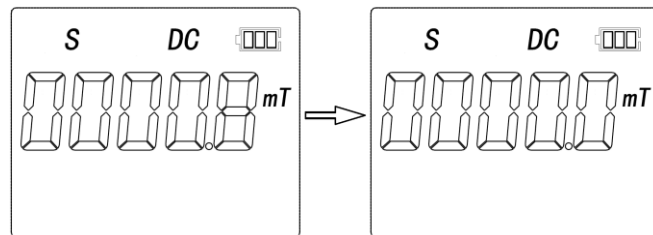

Note: You must reset the Gaussmeter before you start a new measurement after you have changed the measuring range (12) and AC/DC mode (11).

- 8) **Select Max/Min hold** by pressing the “Min/Max” button (6).

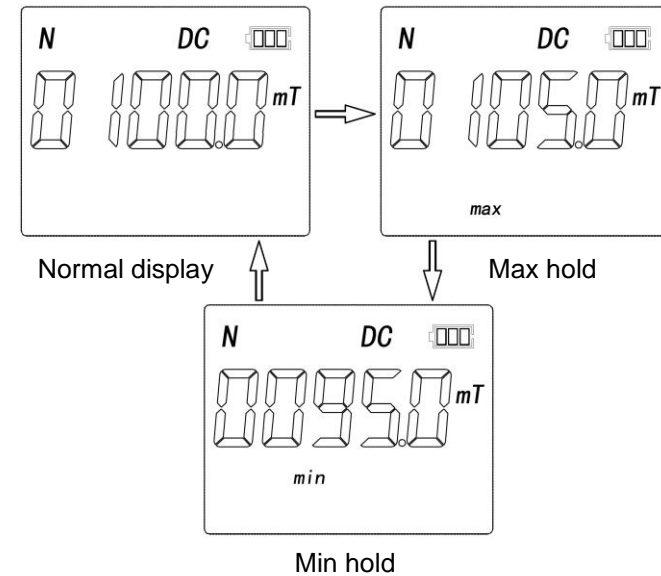

Note: Under the Max/Min mode the display changes only when the actual measuring value is larger/smaller than the last value displayed. Therefore you must firstly reset to the normal mode by using button (6), if you need to measure a magnetic field, which is smaller/larger than the previously measured value.

- 9) **Select display format of AC signal** by using the “RMS/Peak” button (5). The measuring results are shown in RMS or peak value as follows:

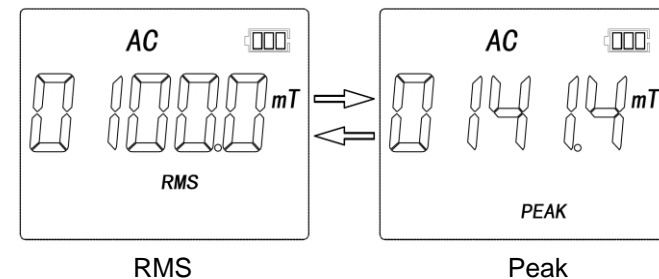

Note: AC measuring results are assumed as sinusoid magnetic field signal. The RMS or amplitude of fundamental wave is displayed on LCD.

10) **Display hold** can be selected by pressing “Hold” button (10).

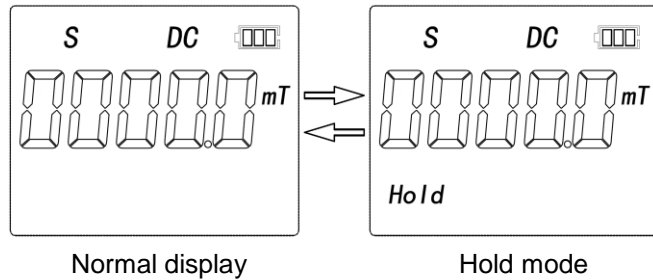

11) Take off the protective tube of the Hall probe, position the Hall probe (14) on the surface of the measuring object (such as permanent magnet), and read the display value (measuring value and pole display “N” or “S”, N for north pole, S for south pole).

Note: The magnetic pole of the measuring object is north if the display shows “N” while the label side of a transverse Hall probe is faced towards the surface of the measuring object. In this case you can read the mark SONNECY of the Hall probe (see picture below).

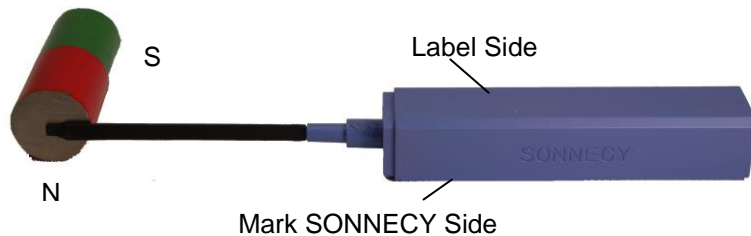

The magnetic pole of the measuring object is N pole if the display shows “N” when the end of an axial Hall probe is put on the surface of the measuring object.

- 12) After the measurement please put the protective tube on the Hall probe in order to protect the Hall element and switch off the power
- 13) The Hall probes delivered are calibrated by using an identical reference Gaussmeter CYGM99B. Therefore all of our Hall probes are compatible for the Gaussmeter CYGM99B.

9. Control with PC

- 1) Connect the measuring instrument (9) to PC via USB cable and install the CH340G driver for new detected device. This measuring device is identified as a serial port COMx.
- 2) The measuring instrument has a full duplex serial port, which is configured with 500kHz Baudrate, no parity check and one stop bit. User can send following ASCII code to select corresponding functions.

No.	ASCII Code	Explanation (for CYTP98B and CYAP98B)
1	I	change to larger measuring range
2	J	change to smaller measuring range
3	A	AC magnetic field
4	D	DC magnetic field
5	Z	Zero reset
6	M	Max hold
7	W	Min hold
8	R	RMS value for AC measuring
9	P	Peak value for AC measuring
10	O	Hold mode
11	Y	Normal display
12	C	Remote control (PC)
13	K	Local control (keypad)
14	B	Start sending data to PC
15	E	Stop sending data to PC
16	H	High-speed mode
17	N	Normal-speed mode

Note: All ASCII codes have to be followed by the \r\n carriage return/newline pattern to be recognized.

- 3) In order to enable the remote control, “C” must be sent firstly. The measuring instrument is back to local control, when “K” is sent or “Local/Remote” button (7) is pressed.

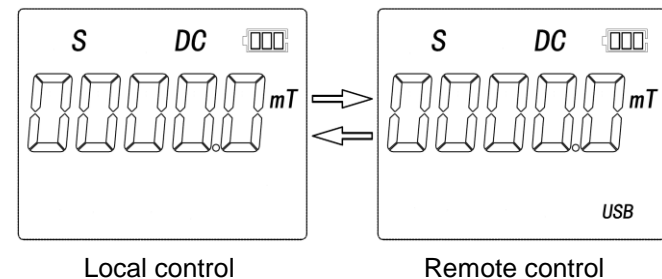

In the remote control mode all ASCII instructions can be responded. Remote control instructions 1-11 are identical with keypad functions. Therefore the rest of instructions should be only explained in following.

- 4) **Enable or disable data sending** by using “B” or “E” instruction. The measuring results in unit “mT” are sent to the computer continuously. The sampling frequency is 1024 samples per second. (Data format is shown in chapter 10.)

Note: The instantaneous values are sent to PC via USB. It means that the received value should be identical to the value shown on LCD in DC mode. But in AC mode, the received data is the instantaneous value of AC magnetic field, which is different from the RMS or peak value shown on LCD.

- 5) **Interchange between normal mode and high-speed mode:**

The "H" and "N" commands can be used to switch between normal and high-speed modes for data transmission. "N" changes to normal mode, "H" to high speed mode.

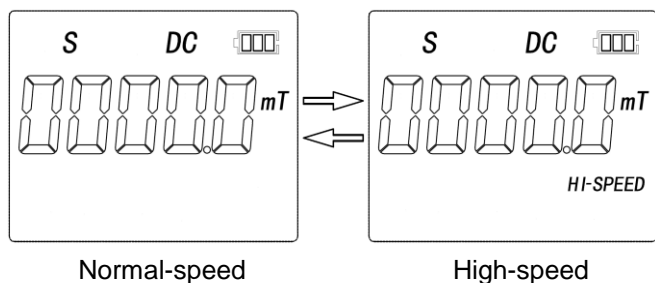

10. Data Format

When data sending is enabled, the measuring instrument sends data to PC continuously, which indicates the instantaneous value of magnetic field in unit “mT”. The sending frequency for normal mode is 2 samples/s, whereas in high-speed mode the sending frequency equals 1024 samples/s.

- 1) In normal-speed mode the measuring results are sent as well as the status of the Gaussmeter. Data packages of 4 Bytes each are sent.

Measuring results consist of the sign, the prefix part and the decimal part. The gaussmeter states are sent right after the result.

sign	CRC	controlbyte
2 Bytes	1 Byte	1 Byte

prefix part	CRC	controlbyte
2 Bytes	1 Byte	1 Byte

decimal part	CRC	controlbyte
2 Byte	1 Byte	1 Byte

Measuring range	CRC	controlbyte
2 Bytes	1 Byte	1 Byte

Battery capacity	CRC	controlbyte
2 Bytes	1 Byte	1 Byte

local/remote	CRC	controlbyte
2 Bytes	1 Byte	1 Byte

measuring mode	CRC	controlbyte
2 Bytes	1 Byte	1 Byte

unit [mT/Gs]	CRC	controlbyte
2 Bytes	1 Byte	1 Byte

hold mode	CRC	controlbyte
2 Bytes	1 Byte	1 Byte

Note: every 4-Byte package is masked with 0xC0 at the beginning of the package.

The different states of Gaussmeter are explained in the following table:

Status	Hexcode
Unit: mT	0x80C5
Unit: Gs	0x80C6
No probe connected	0x80B1
50mT probe conn.	0x80B2
500mT probe conn	0x80B3
200mT probe conn	0x80B4

2000mT probe conn	0x80B5
300mT probe conn	0x80BC
3000mT probe conn	0x80BD
normal DC mode	0x8070
max. Hold mode	0x8071
min. Hold mode	0x8072
AC RMS mode	0x8073
AC Peak mode	0x8074
Hold mode on	0x8075
Hold mode off	0x8076

1) In **highspeed mode**, the average of 40 ADC measurements is sent as a float number. The sampling rate in this mode is 1kHz.

measurement result
4 Bytes

11. Packing List



Net weight: 735g



- 1 1x CYGM99B incl. 1x LiPo battery
- 2 1 x Hall probe CYAP98[A/B/C] or CYTP98[A/B/C]
- 3 2 x 0.9m USB Cable
- 4 1 x 5V DC Voltage adapter

12. Warranty

Measuring instrument:	12 months
Hall sensor/probe:	no guarantee. However we offer you Replacement for reduced price (10% discount)

Please contact us for technical questions, repairing and replacement etc.

ChenYang Technologies GmbH & Co. KG
 Markt Schwabener Str. 8
 85464 Finsing, Germany
 Tel. +49-(0)8121-2574100
 Fax: +49-(0)8121-2574101
 Email: info@chenyang.de
<https://www.chenyang-gmbh.com>